

voorgevel.

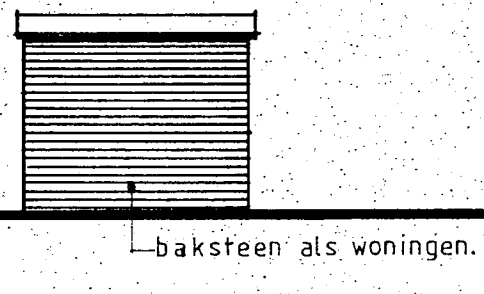

zijgevels.

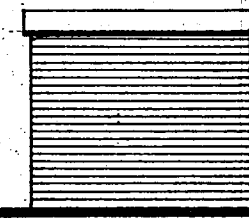

achtergevel.

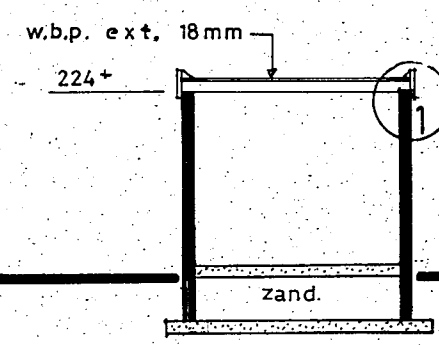

doorsnede.

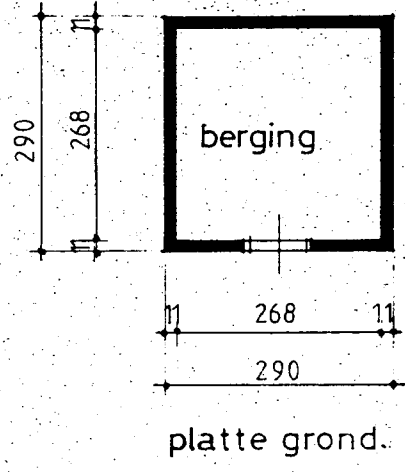

platte grond.



fundering.

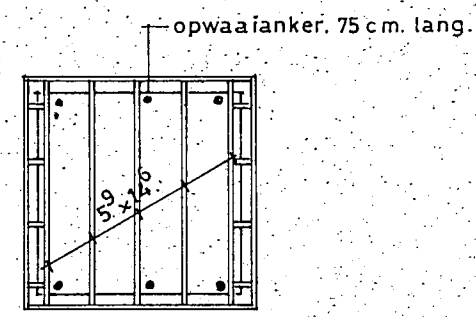

kapplan.

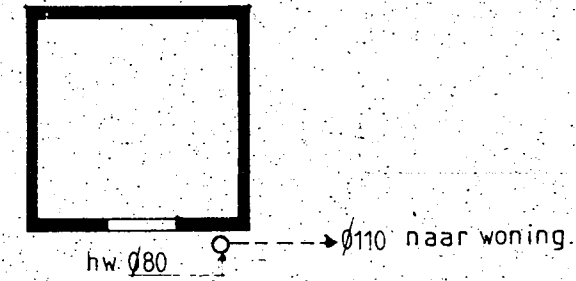

beg. grondvloer.

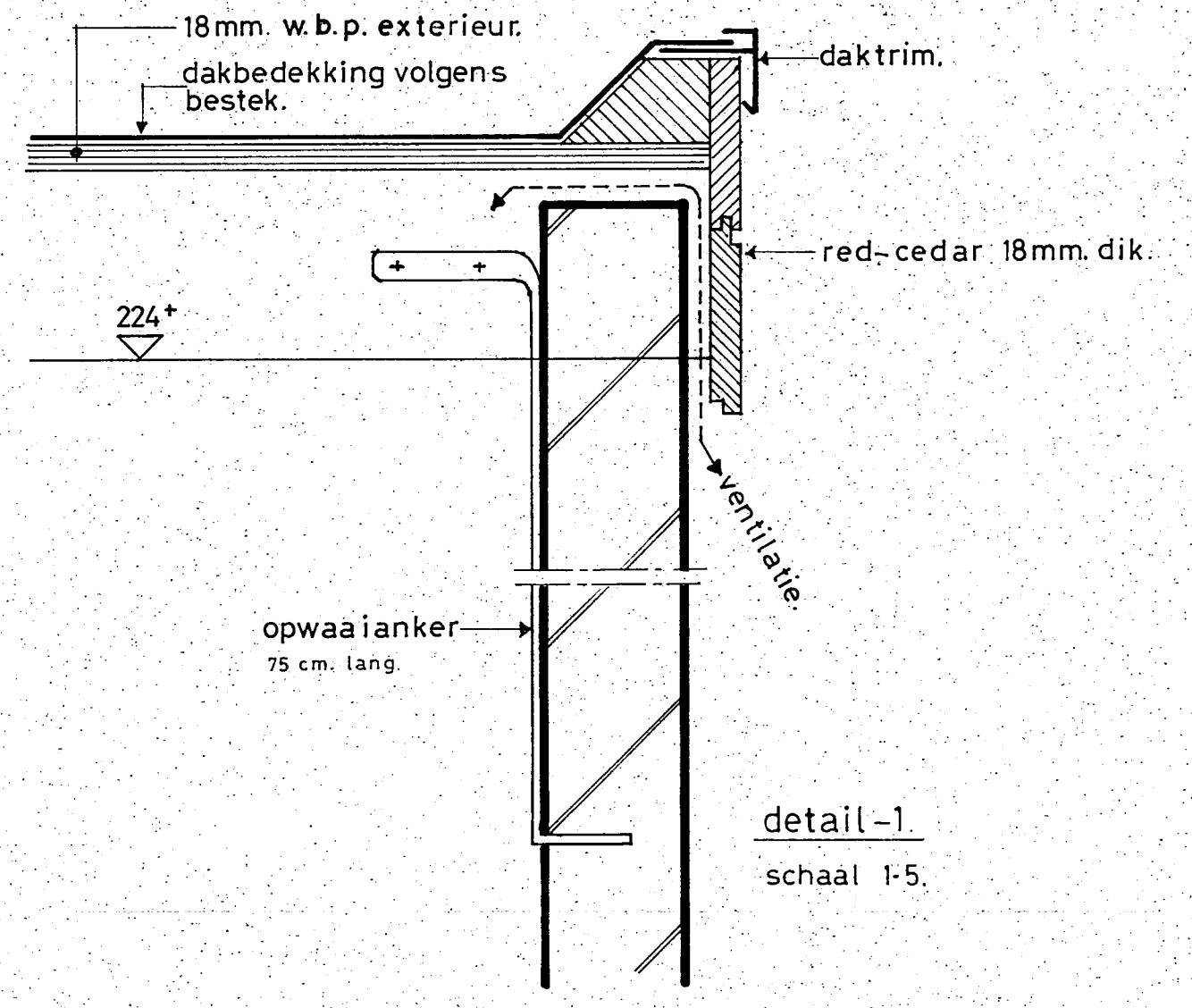

detail-1
schaal 1-5.

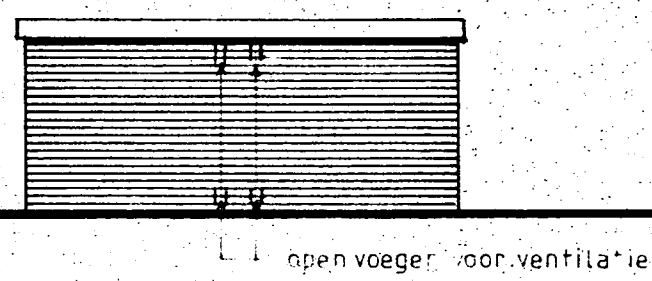

zijgevel.

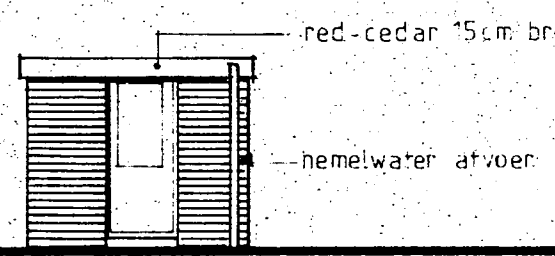

voorgevel.

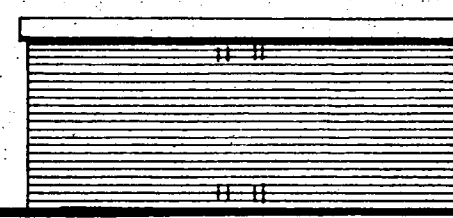

zijgevel.

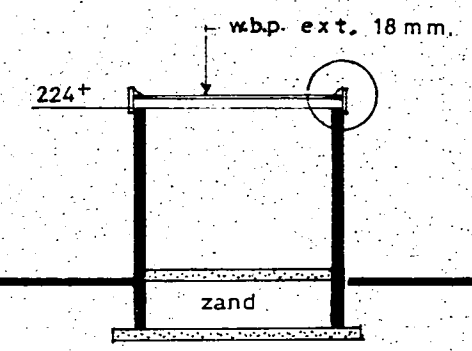

doorsnede.

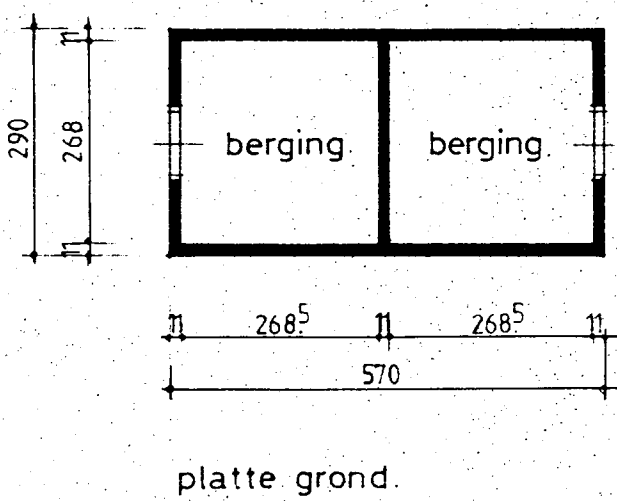

platte grond.

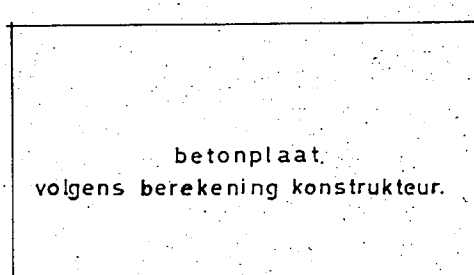

fundering.

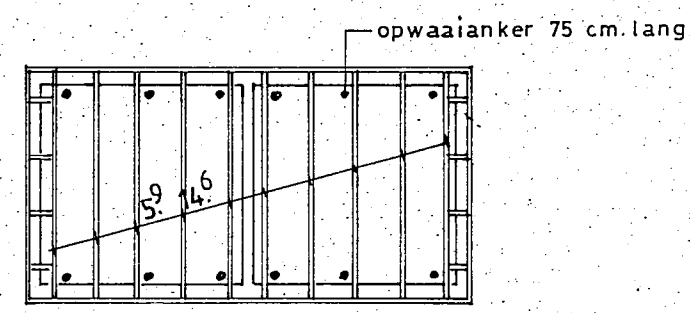

kapplan.

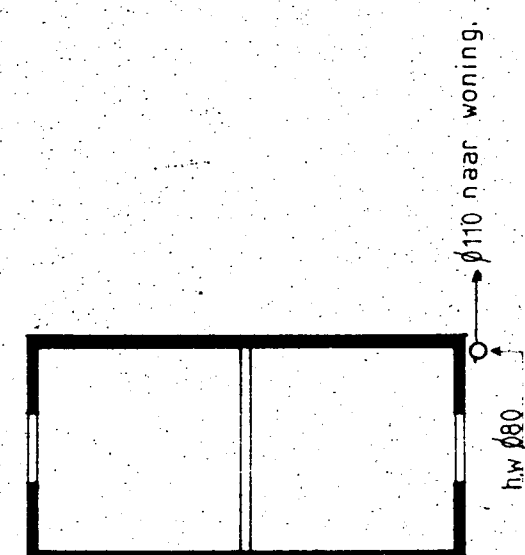

beg. grondvloer.

Behoort bij besluit van
de Raad
B. en VV. van Heemskerk
dd. 20 april 1985 no. 72
Mij bekend.
De Secretaris van Heemskerk,

[Handwritten signature]

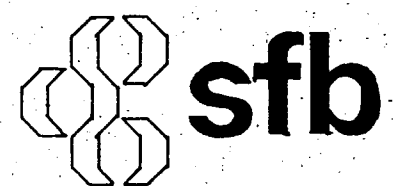

FASE-2.

plan voor het bouwen van 43 woningen te Heemskerk-Breedweer						get: vb	
opdrachtgever: stichting bedrijfspensioenfonds voor de bouwnijverheid te Amsterdam.						schaal: 1-100 1-5	
onderwerp: enkele en dubbele berging				STANDAARD		datum: 13-2-84	
 architectenbureau van blokland alexander verhuellstraat 18a 6717jb ede telefoon 08380-32474						werknnummer 6-83	
						bladnummer 9.	
wijz. datum	a 27-2-84 g	b h	c i	d j	e k	f l	formaat: 58x80